

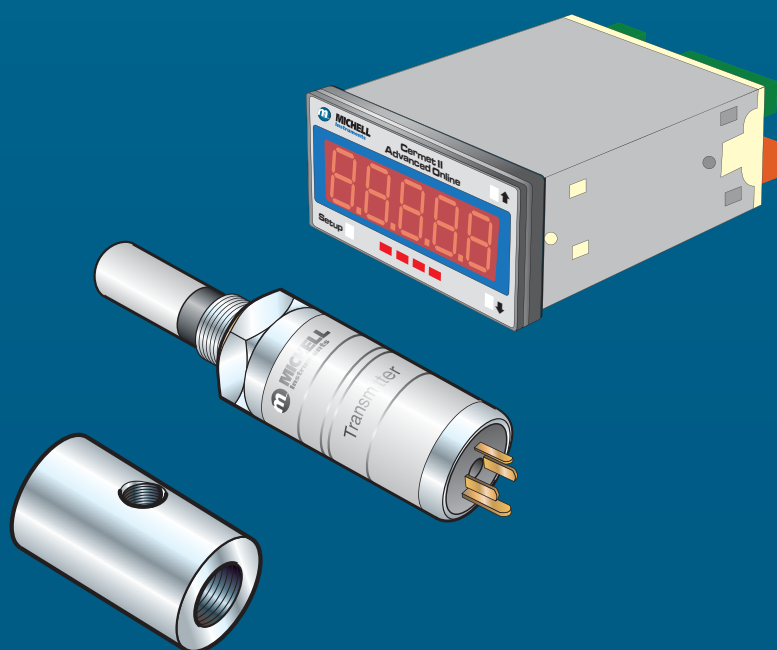

# Cermet II Hygrometer User's Manual



97049 Issue 25.3  
October 2016

Please fill out the form(s) below for each instrument that has been purchased.

Use this information when contacting Michell Instruments for service purposes.

Instrument	
Code	
Serial Number	
Invoice Date	
Location of Instrument	
Tag No	

Instrument	
Code	
Serial Number	
Invoice Date	
Location of Instrument	
Tag No	

Instrument	
Code	
Serial Number	
Invoice Date	
Location of Instrument	
Tag No	

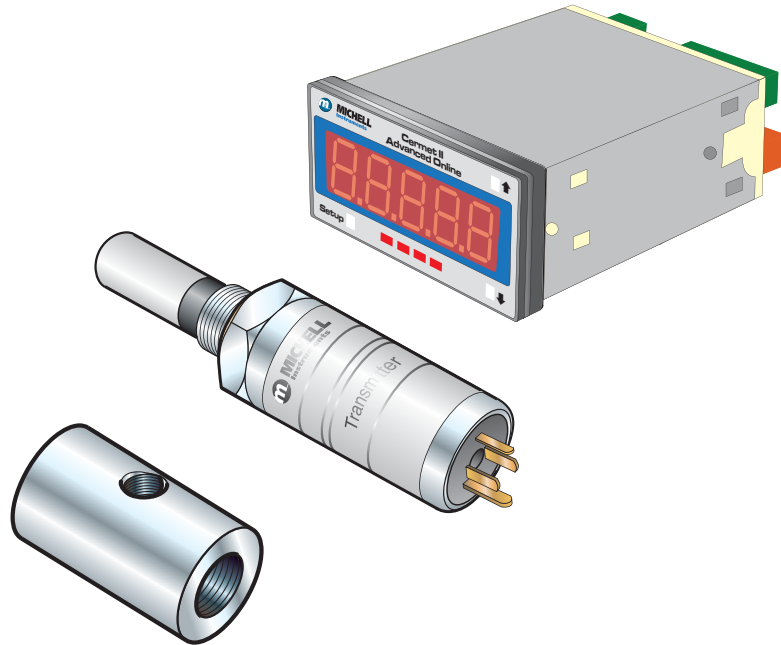

## Cermet II

For Michell Instruments' contact information please go to  
[www.michell.com](http://www.michell.com)

© 2016 Michell Instruments

This document is the property of Michell Instruments Ltd. and may not be copied or otherwise reproduced, communicated in any way to third parties, nor stored in any Data Processing System without the express written authorization of Michell Instruments Ltd.

---

## Contents

Safety .....	vi
Electrical Safety .....	vi
Pressure Safety .....	vi
Toxic Materials .....	vi
Repair and Maintenance .....	vi
Calibration .....	vi
Safety Conformity .....	vi
Abbreviations .....	vii
Warnings .....	vii
1 INTRODUCTION .....	1
1.1 Features .....	1
2 INSTALLATION .....	2
2.1 Unpacking the Instrument.....	2
2.1.1 Unpacking the Cermet II Transmitter .....	3
2.1.2 Unpacking the Cermet II Monitor .....	4
2.1.3 Accessories Pack .....	4
2.2 Cermet II Components .....	5
2.3 Monitor.....	6
2.4 Monitor Panel Layout .....	6
2.5 Preparation of the Transmitter Cable .....	7
2.6 Transmitter Mounting.....	8
2.6.1 Transmitter Mounting - Sample Block and Gas Connections (Optional) .....	9
2.6.2 Transmitter Mounting - Direct Pipeline Connection .....	11
2.6.3 Transmitter Mounting - With Additional Process Connection Adapter .....	12
2.7 Monitor Mounting .....	13
2.8 Electrical Connections .....	14
2.8.1 High Voltage Power Supply Input .....	14
2.8.2 Low Voltage Power Supply Input .....	15
2.9 Pressure Transducer Connection (Optional) .....	15
2.10 Transmitter Cable Connection .....	16
3 OPERATION - MONITOR.....	17
3.1 Set-Up Security Feature .....	17
3.2 Selecting the Engineering Units .....	18
3.3 Changing the Setpoint Values .....	18
3.4 Hysteresis, Make/Break delay & delay type.....	19
3.5 Analog Output Scaling .....	19
3.6 Display Brightness Adjustment .....	20
3.7 Digital Communications.....	20
3.8 Pressure Compensation.....	21
3.9 Using a Pressure Transducer .....	21
3.9.1 Manual Pressure Input Calibration .....	22
3.10 Automatic Pressure Input Calibration .....	22
3.11 Using a Fixed Pressure Input in Single Channel Mode.....	23
4 OPERATION - TRANSMITTER.....	24
5 MAINTENANCE .....	25

## Figures

Figure 1	Unpacking - Monitor and Accessories .....	2
Figure 2	Transmitter Unpacking Method .....	3
Figure 3	Unpacking - Monitor .....	4
Figure 4	Unpacking - Accessories Pack .....	4
Figure 5	Components.....	5
Figure 6	Control Layout and Functions .....	6
Figure 7	Connector Terminal Block Removal .....	7
Figure 8	Sample Block Gas Connections .....	9
Figure 9	Transmitter Mounting - Sensor Block.....	10
Figure 10	Transmitter Mounting - Pipe or Duct.....	11
Figure 11	Transmitter Mounting with Adapter .....	12
Figure 12	Mounting the Monitor .....	13
Figure 13	High Voltage Power Supply Connections.....	14
Figure 14	Low Voltage Power Supply Connections.....	15
Figure 15	Electrical Connection Detail .....	15
Figure 16	Cable Connections .....	16
Figure 17	Connector Installation.....	16
Figure 18	Location of the Lockout Switches.....	17
Figure 19	Installation Location .....	24
Figure 20	Indication of Dead Space .....	24
Figure 21	Replacement of HDPE Guard .....	25

## Tables

Table 1	Cable Connections.....	16
Table 2	Operation Access Levels.....	17

## Appendices

Appendix A	Technical Specifications.....	27
Appendix B	Setup Codes .....	30
Appendix C	Register Settings Accessible by Digital Communication .....	33
Appendix D	EU Declaration of Conformity.....	36
Appendix E	Quality, Recycling & Warranty Information.....	38
E.1	Pressure Equipment Directive (PED) 97/23/EC .....	38
E.2	Recycling Policy .....	38
E.3	WEEE Compliance.....	38
E.4	RoHS2 Compliance .....	39
E.5	Warranty.....	39
E.6	REACH Compliance .....	40
E.7	Return Policy .....	40
E.8	Calibration Facilities .....	41
E.9	Manufacturing Quality .....	41
E.10	FCC (EMC REquirements for North America) .....	41
Appendix F	Return Document & Decontamination Declaration.....	43

## Safety

The manufacturer has designed this equipment to be safe when operated using the procedures detailed in this manual. The user must not use this equipment for any other purpose than that stated. Do not apply values greater than the maximum value stated.

This manual contains operating and safety instructions, which must be followed to ensure the safe operation and to maintain the equipment in a safe condition. The safety instructions are either warnings or cautions issued to protect the user and the equipment from injury or damage. Use qualified personnel and good engineering practice for all procedures in this manual.

## Electrical Safety

The instrument is designed to be completely safe when used with options and accessories supplied by the manufacturer for use with the instrument.

## Pressure Safety

DO NOT permit pressures greater than the safe working pressure to be applied to the instrument. The specified safe working pressure is 45 MPa (450 barg / 6500 psig). Refer to the Technical Specifications in Appendix A.

## Toxic Materials

The use of hazardous materials in the construction of this instrument has been minimized. During normal operation it is not possible for the user to come into contact with any hazardous substance which might be employed in the construction of the instrument. Care should, however, be exercised during maintenance and the disposal of certain parts.

## Repair and Maintenance

The instrument must be maintained either by the manufacturer or an accredited service agent. Refer to [www.michell.com](http://www.michell.com) for details of Michell Instruments' worldwide offices contact information.

## Calibration

The recommended calibration interval for the Cermet II transmitter is 12 months unless it is to be used in a mission-critical application or in a dirty or contaminated environment in which case the calibration interval should be reduced accordingly. The instrument should be returned to the manufacturer, Michell Instruments Ltd., or one of their accredited service agents for re-calibration.

Michell Instruments can offer a variety of re-calibration and exchange transmitter schemes to suit your specific needs. A local representative will be pleased to provide detailed, custom advice.

## Safety Conformity

This product meets the essential protection requirements of the relevant EU directives.

## Abbreviations

The following abbreviations are used in this manual:

AC	alternating current
atm	pressure unit (atmosphere)
barg	pressure unit (=100 kP or 0.987 atm) (gauge)
DC	direct current
EU	European Union
g/m <sup>3</sup>	grams per cubic meter
Hz	Hertz
lb	pound
lbs/MMSCF	pounds per million standard cubic feet
l/min	liters per minute
mA	milliampere
Nm	nanometer
ppm <sub>v</sub>	parts per million (by volume)
psig	pound(s) per square inch (gauge)
sec	second(s)
°C	degrees Celsius
°F	degrees Fahrenheit
V	Volts

## Warnings

The following general warnings listed below are applicable to this instrument. They are repeated in the text in the appropriate locations.



**Where this hazard warning symbol appears in the following sections, it is used to indicate areas where potentially hazardous operations need to be carried out.**



**Where this symbol appears in the following sections it is used to indicate areas of potential risk of electric shock.**

## 1 INTRODUCTION

The Cermet II hygrometer is an instrument designed for the continuous online measurement of moisture content in non-corrosive gases, over an operational range of -100 to +20°C (-148 to +68°F) dew point and equivalent units (see Technical Specifications, Appendix A).

The system comprises a programmable monitor configured to accept a unique Michell data string from the Cermet II transmitter. The zero and span of the monitor are set to cover the dew-point range -100 to +20°Cdp (-148 to +68°Fdp) at operating pressures up to 45 MPa (450 barg / 6500 psig).

Two alarm outputs are provided for connection to external systems which are user-configurable both in terms of setpoint and operating mode. Current output is standard and factory set at 4-20 mA (or optionally set at 0-20 mA or 0-10 V).

The monitor has a pressure input channel for any industry standard 2-wire pressure transmitter. In addition to providing a pressure measurement, the pressure signal can be used to provide real-time pressure compensation on the primary channel when displaying ppm values. The customer can also set a fixed pressure compensation value. The pressure input only affects the ppm<sub>v</sub> (parts per million by volume), lbs/MMSCF (pounds per million standard cubic feet) and g/m<sup>3</sup> (grams per cubic meter) units. For dew point, the displayed value is a pressure dew point.

### 1.1 Features

- Wide measurement range, calibrated -100 to +20°Cdp
- ±1°Cdp measurement accuracy
- Pressure sensor input
- Up to 4 alarm relays
- User selectable units of measurement
- Easy to read display
- Analog and digital outputs

2 INSTALLATION



**It is essential that the connection of electrical and gas supplies to this instrument be undertaken by competent personnel.**

2.1 Unpacking the Instrument

The Cermet II hygrometer and accessories are packed in a box and the method of unpacking is shown as follows:

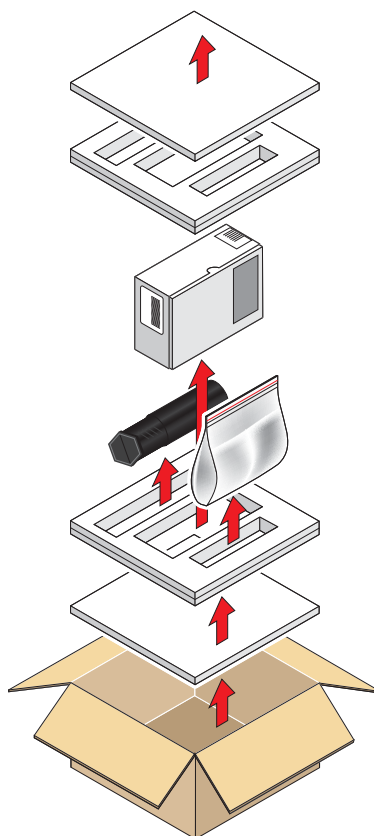

**Figure 1** *Unpacking - Monitor and Accessories*

### 2.1.1 Unpacking the Cermet II Transmitter

On delivery, check that all the following standard components are in the packing tube:

- Cermet II Transmitter
- Bonded Seal
- Certificate of Calibration

Unpack the dew-point transmitter tube as follows:

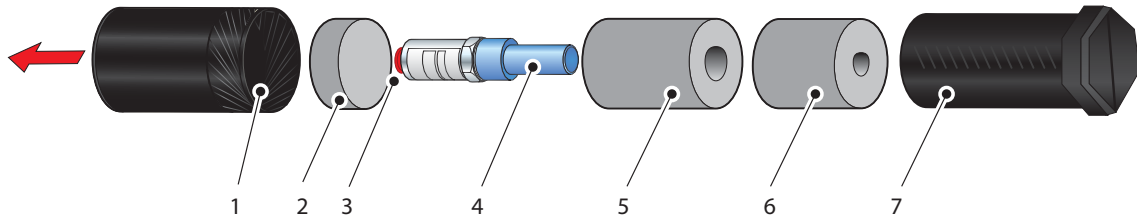

**Figure 2** *Transmitter Unpacking Method*

1. Unscrew the cap (1) from the packing tube (7).
2. Remove the foam block (2).
3. Pull out the transmitter (4) from the tube, complete with the two foam covers (5) and (6) and the red protective cap (3).
4. Remove the foam covers from the transmitter but leave the blue plastic protective cover (4) and the red cap (3) in place until ready for installation.

**NOTE: The transmitter sensing element is protected while in transit by a blue cover containing a small desiccant capsule. The connection pins are protected by a red plastic cap. None of these plastic items are required for the operation of the transmitter.**

### 2.1.2 Unpacking the Cermet II Monitor

The monitor (2) is packed, together with its fixing clamps (1) as shown below.

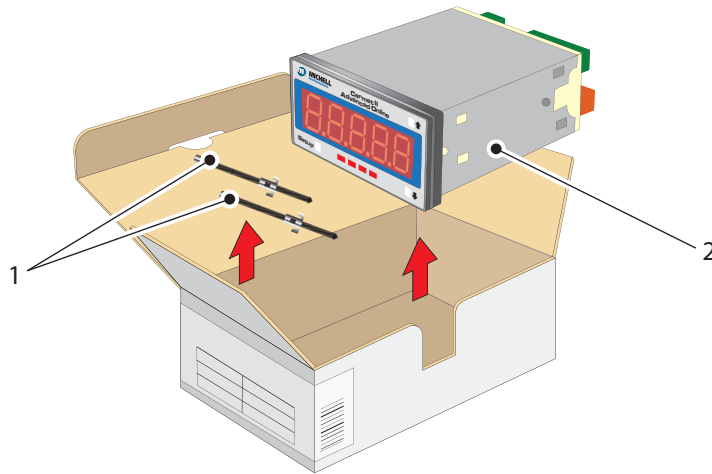

**Figure 3** *Unpacking - Monitor*

### 2.1.3 Accessories Pack

The accessories pack is shown below:

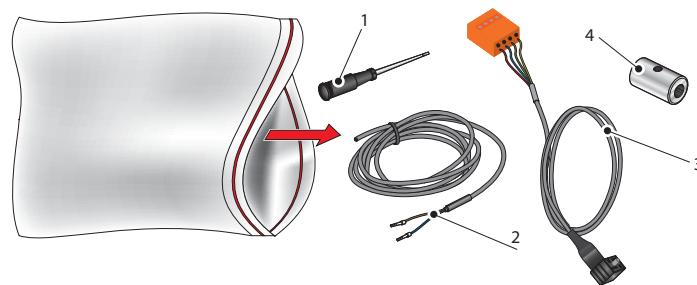

**Figure 4** *Unpacking - Accessories Pack*

## 2.2 Cermet II Components

On delivery, please check that all the following standard components are present in the packing box. Report any shortages immediately.

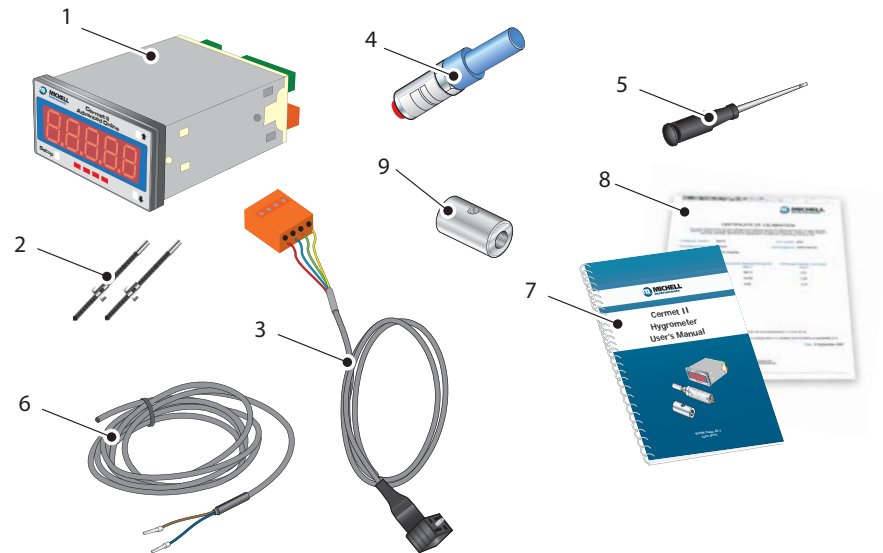

**Figure 5** *Components*

1. Cermet II Monitor
2. Clamps
3. Transmitter cable assembly
4. Cermet II Transmitter
5. Screwdriver
6. Power cable
7. User's manual
8. Calibration certificate
9. Sample block

### 2.3 Monitor

The monitor has a 5-digit display, set-up on delivery to display a dew-point temperature range of -100° to +20°Cdp (-148° to +68°Fdp).

Dew-point temperature units are displayed by the last LED located to the far right of the display. On delivery, °Cdp is set-up. If required, the units can be changed to °F. The method of configuring the unit for °F is described in Section 3.2.

Optionally, the instrument can be set-up to read moisture content in parts per million (ppmV), pounds per million standard cubic feet (lbs/MMSCF) or grams per cubic meter (g/m3). This option requires the hygrometer to be set-up as detailed in Section 3.2.

Four alarm indications are provided by four LEDs located on the bottom of the display. These are marked SP1, SP2, SP3, SP4. Access to the alarm relay contacts is provided on the rear panel. The connection for these alarm relay contacts is shown in *Figure 15*.

**NOTE: Every monitor is factory fitted with 2 alarm relays as standard.**

### 2.4 Monitor Panel Layout

*Figure 6* shows the layout of these controls and their respective operational functions.

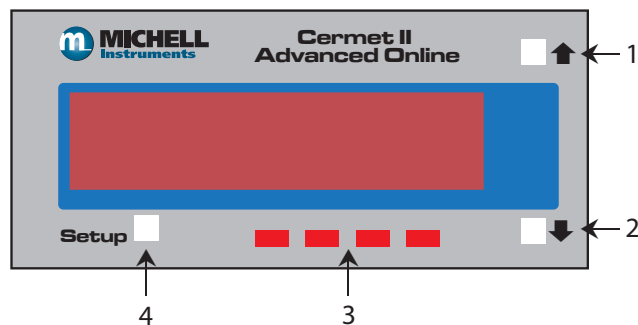

1	Increases the value of the displayed parameter; moves through each displayed parameter
2	Decreases the value of the displayed parameter; moves through each displayed parameter
3	LED annunciations for Setpoints 1 - 4
4	Saves programming settings, moves between programming steps

**Figure 6** Control Layout and Functions

## 2.5 Preparation of the Transmitter Cable

The transmitter cable is supplied as standard. Replacement of additional cables can be obtained by contacting your local distributor or Michell Instruments (see [www.michell.com](http://www.michell.com) for details).

The cable is pre-wired so no user wiring is required. If the cable needs to be re-wired, see below:

Cable connection to the Cermet II transmitter is made via the removable connector. Removing the central screw enables the connector terminal block to be removed from the outer housing by using a small screwdriver to prise it clear.

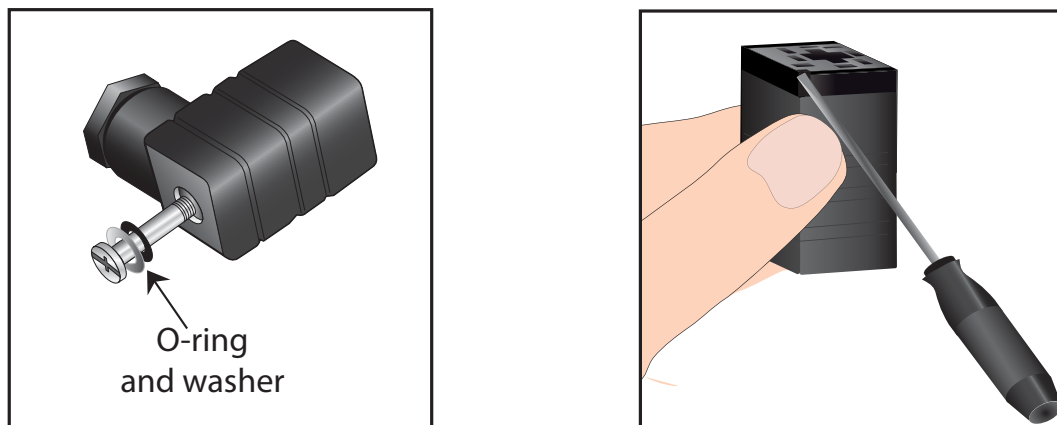

**Figure 7** *Connector Terminal Block Removal*



**Caution: When removing the central screw ensure that the small sealing O-ring and the washer are retained on the screw and are present during re-installation.**

## 2.6 Transmitter Mounting

Prior to installation of the transmitter, unscrew and remove the blue plastic cover and retain for future use. Take care to prevent any contamination of the transmitter before installation (handle the transmitter by the main body only, avoiding contact with the sensor guard).

The transmitter can be mounted into either a flow-through sampling block (optional) or directly inserted into a pipe or duct and can be operated at pressures of up to 45 MPa (450 barg / 6500 psig) when fitted with the bonded seal provided.

The recommended gas flow rate, when mounted in the optional sampling block, is 1 to 5 NI/min (2.1 to 10.6 scfh). However, for direct insertion applications, gas flow can be from static to 10 m/sec (32.8 fps).

**NOTE: Pass the bonded seal over the 5/8"- 18 UNF mounting thread and assemble into the sampling location by hand using the wrench flats only. DO NOT grip and twist the transmitter cover when installing the transmitter.**

When installed, fully tighten using a wrench until the seal is fully compressed and to the following torque setting:

5/8" - 18 UNF                      30.5 Nm (22.5 ft-lbs)

### 2.6.1 Transmitter Mounting - Sample Block and Gas Connections (Optional)

Sample gas connections are made to the Gas In and Gas Out ports on the sample block see *Figure 8*. Either port on the sample block may be used as the Gas Input port (i.e. for connection purposes the ports are interchangeable).

Normally, connections are made via stainless steel pipework, in which case the sensor block/transmitter assembly will be self supporting. If Teflon tubing is used it may be necessary to support the assembly with a body clip.

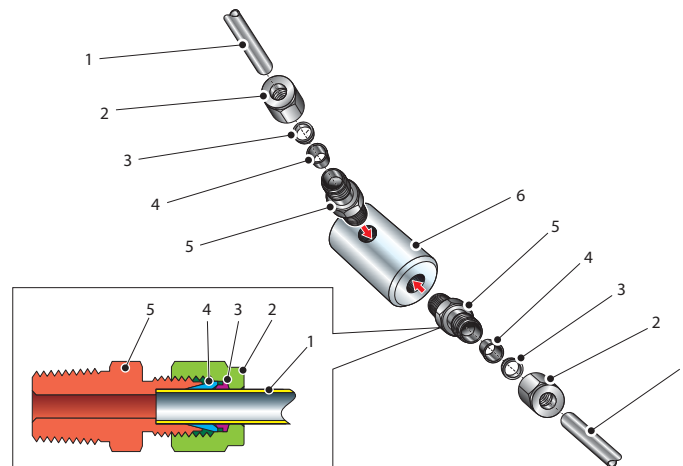

**Figure 8** *Sample Block Gas Connections*

Both the Input and Output gas connections are  $\frac{1}{8}$ " NPT. It is recommended that both the Gas Input and Output connections are made via  $\frac{1}{8}$ " NPT to 6mm or  $\frac{1}{8}$ " NPT to  $\frac{1}{4}$ " stainless steel tube adaptors (2 to 5 - *Figure 8*). The method of connection to the sensor block (6) is as follows:

**NOTE: The following description relates to 6mm tube fixings. The sample block ports are both  $\frac{1}{8}$ " NPT female process connections. Tube adaptors are not supplied with the equipment but can be obtained by contacting your local distributor or Michell Instruments (see [www.michell.com](http://www.michell.com) for details).**

1. Cut a suitable length of 6mm ( $\frac{1}{4}$ " U.S.) stainless steel tubing (1) to the correct length and, if necessary, bend to shape to suit the location of the sensor block assembly. **NOTE: To facilitate ease of connection to the port, at least 75mm (3") of the tubing coming out of the Gas In port must be straight.**
2. Clean off any burrs or metal shavings adhering to the tubing.
3. Screw the  $\frac{1}{8}$ " NPT ( $\frac{1}{4}$ " U.S.) NPT Swagelok adaptor (5) into the  $\frac{1}{8}$ " NPT ( $\frac{1}{4}$ " U.S.) NPT inlet port in the sensor block (6) and tighten to a torque setting of 35 Nm (25 lbf-ft).
4. Pass the stainless steel tubing (1) through the locking nut (2). **NOTE: Threads towards the gas port.**
5. Fit the back ferrule (3) over the stainless steel tubing (1) with the bevelled end facing the back of the front ferrule (4).
6. Place the front ferrule (4) over the stainless steel tubing (1), bevelled end towards the adaptor (5).

7. Push the stainless steel tubing (1) as far as it will go into the adaptor (5) and tighten up the locking nut (2) finger tight.
8. Hold the adaptor (5) flats with a spanner and tighten up the locking nut (2) to a torque setting of 35 Nm (25 lbf-ft) (1¼ turns). This action compresses the front ferrule (4) and back ferrule (3) onto the tubing to form a gas tight seal.
9. Connect up the other gas port as described in steps 1 to 8 above.



**The following procedure must be carried out by a qualified installation engineer.**

To mount the transmitter into the sample block (preferred method), proceed as follows, refer to *Figure 9*.

1. Remove the blue protective cover (2) and its desiccant capsule (2a), from the tip of the transmitter.
2. Fit the bonded seal (3) over the threaded part of the transmitter body.



**WARNING: Under no circumstances should the sensor guard be handled with the fingers.**

3. Screw the transmitter (1) into the sample block (4) and tighten to a minimum torque setting of 30.5 Nm (22.5 ft-lbs). **NOTE: Use the flats of the hexagonal nut and not the transmitter body.**
4. Fit the transmitter cable/connector assembly to the plug located on the base of the transmitter and tighten the fixing screw (see Section 2.10).

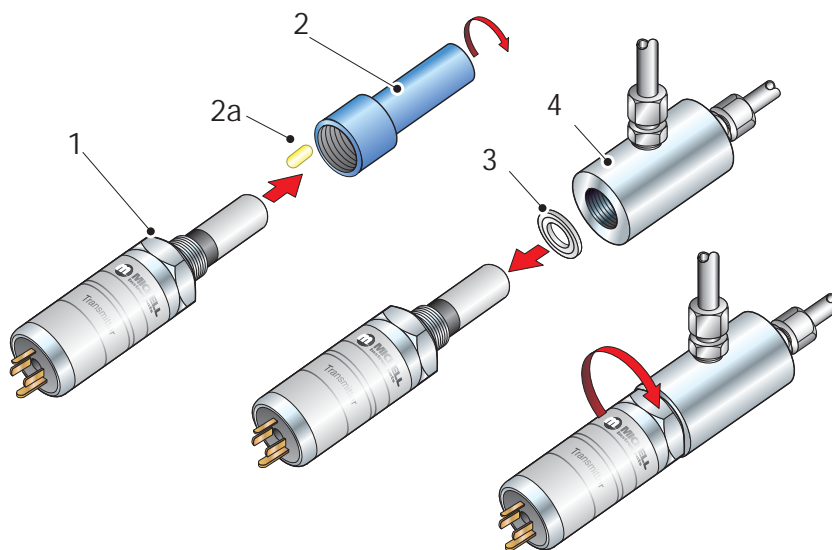

**Figure 9** *Transmitter Mounting - Sensor Block*

### 2.6.2 Transmitter Mounting - Direct Pipeline Connection

The transmitter may be directly mounted into a pipe or duct, as shown in *Figure 10*.



**CAUTION: Do not mount the transmitter too close to the bottom of a bend where any condensate in the pipeline might collect and saturate the probe.**

The pipe or duct will require a thread to match the transmitter body thread. Fixing dimensions are shown in *Figure 10*. For circular pipework, to ensure the integrity of a gas tight seal, a mounting flange will be required on the pipework in order to provide a flat surface to seal against.



**The following procedure must be carried out by competent personnel.**

1. Ensure that the blue protective cover (and its desiccant capsule) has been removed from the tip of the transmitter.



**WARNING: Under no circumstances should the sensor guard be handled with the fingers.**

2. Fit a bonded seal (2) over the threaded part of the transmitter body.
3. Screw the transmitter (3) into the pipe (1). Tighten enough to obtain a gas tight seal. (Torque will depend upon the pipeline material.) **NOTE: Do not overtighten or the thread on the pipework may be stripped.**

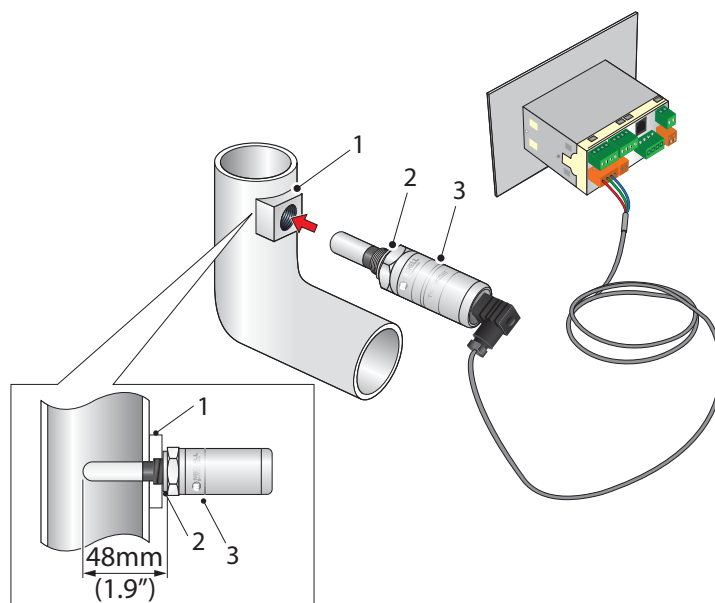

**Figure 10** Transmitter Mounting - Pipe or Duct

2.6.3 Transmitter Mounting - With Additional Process Connection Adapter



The following procedure must be carried out by a qualified installation engineer.

To mount the adapter into the transmitter, proceed as follows (see *Figure 11*) :

1. Ensure that the protective cover (2), and its desiccant capsule (2a), have been removed from the tip of the transmitter.
2. Fit the bonded seal (3) over the threaded part of the transmitter body.
3. Screw the adapter (4) onto the threaded part of the transmitter and tighten to 30.5 Nm (22.5 ft-lbs). **NOTE: Use the flats of the hexagonal nut and not the transmitter body.**



**WARNING: Under no circumstances should the sensor guard be handled with the fingers.**

4. Screw the transmitter (1) with its seal (3) and adapter (4) into the sample block (see Section 2.6.1) or pipeline (see Section 2.6.2) and fully tighten using a wrench until the seal is fully compressed and to the following torque settings:

G 1/2" BSP	56 Nm (41.3 ft-lbs)
3/4" - 16 UNF `	40 Nm (29.5 ft-lbs)
1/2" NPT	Use a suitable sealant e.g. PTFE tape using correct taping procedures

**NOTE: Use the flats of the hexagonal nut and not the transmitter body.**

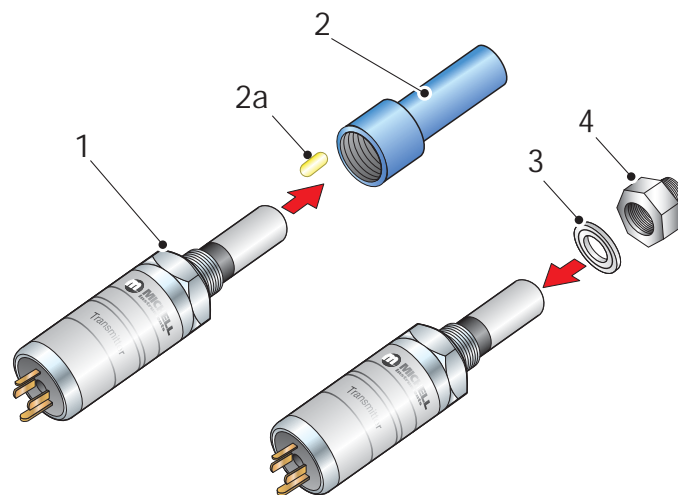
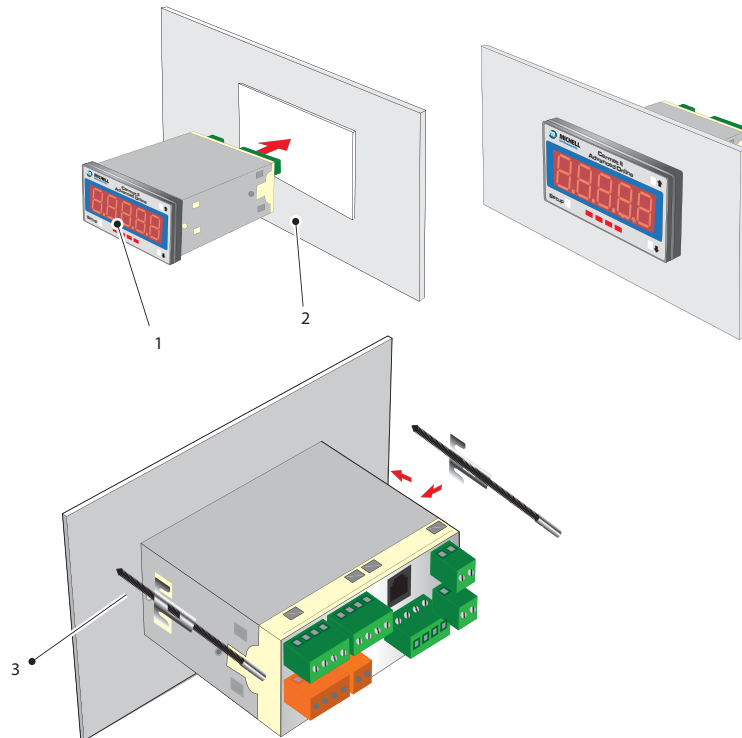

**Figure 11** Transmitter Mounting with Adapter

## 2.7 Monitor Mounting

The monitor is designed for panel mounting and requires a panel cut-out of 46 x 92mm (1.8 x 3.6"). The recommended panel thickness is 2 to 5mm (0.08 to 0.2").

To mount the unit, proceed as follows:



**Figure 12** *Mounting the Monitor*

1. Pass the monitor (1) through the front of the panel (2).
2. Support the monitor and attach mounting fixing brackets onto the side of the monitor.
3. Tighten the fixing screw (3) finger tight, against the back of the panel.
4. Ensure that the monitor is sitting flush to the front of the panel (2) and tighten the fixing screws evenly against the back of the panel.

**Caution: Do not overtighten the screws as this could cause the case to crack.**

## 2.8 Electrical Connections

The power supply voltage is indicated on the connection detail label located on the monitor. As the monitor is provided for continuous operation it does not have an ON/OFF switch.

The power supply to the monitor may be one of the following, dependant on the type ordered.

### 2.8.1 High Voltage Power Supply Input

For high voltage powered display

- 85 to 265 V AC 50/60 Hz and 95 to 370 V DC



**It is essential that the connection of electrical supplies to this instrument be undertaken by competent personnel.**

Connect the power supply to the monitor (1) as shown in *Figure 13*.

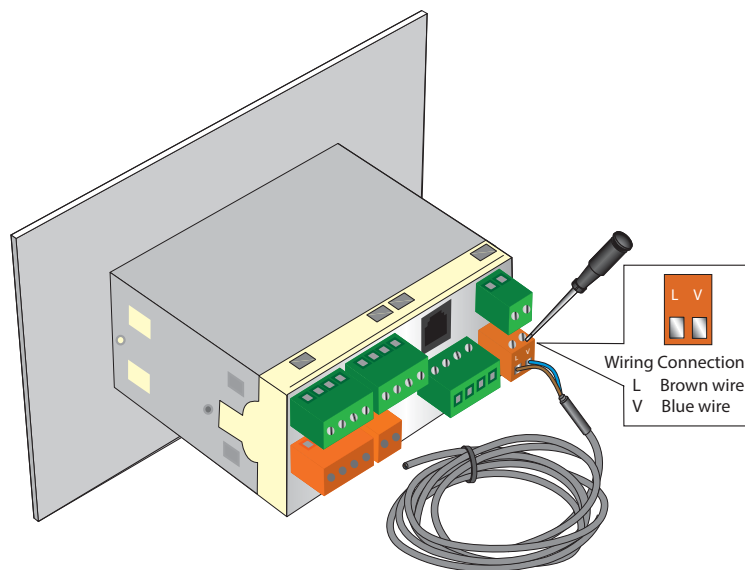

**Figure 13** *High Voltage Power Supply Connections*

**2.8.2 Low Voltage Power Supply Input**

For low voltage powered display

- 18 to 36 V AC and 9 to 60 V DC

Connect the power supply to the monitor (1) as shown in *Figure 14*.

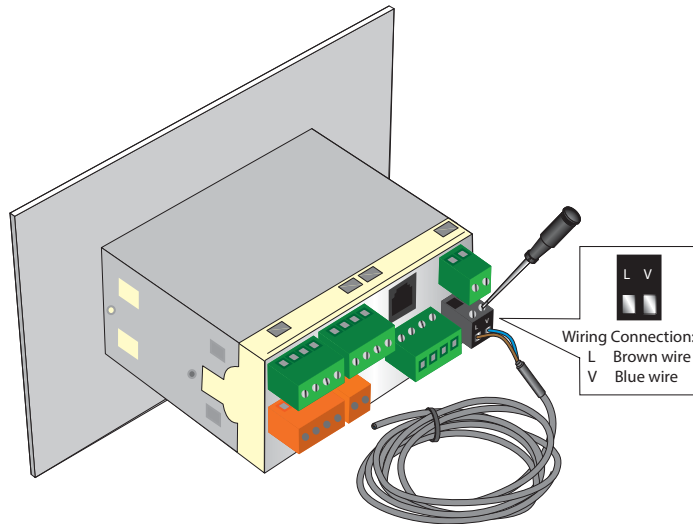

**Figure 14** Low Voltage Power Supply Connections

**2.9 Pressure Transducer Connection (Optional)**

The monitor provides excitation voltage (24 V DC @ 20 mA) for an auxiliary 2-wire transmitter used in the dual channel configuration. Connect (+) of the pressure transmitter to pin 6 of the monitor and (-) of the pressure transmitter to pin 5 of the monitor. Refer to *Figure 15* for details.

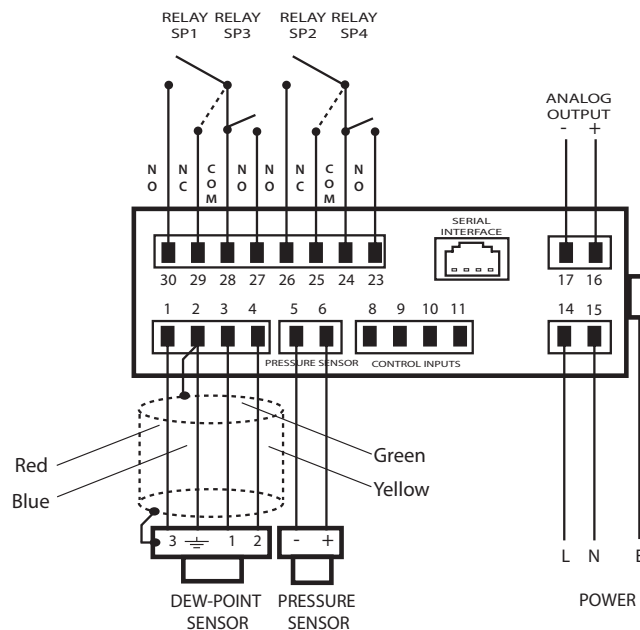

**Figure 15** Electrical Connection Detail

2.10 Transmitter Cable Connection

The diagram below shows the identity of the connector terminals.

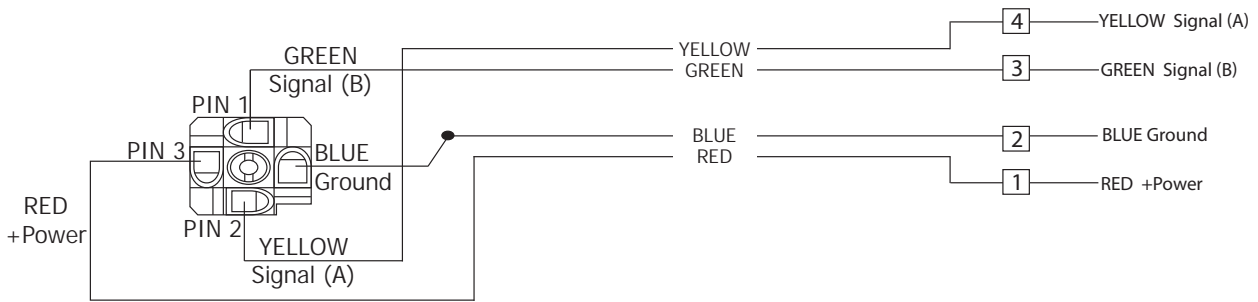

Figure 16 Cable Connections

The transmitter cable connections are shown in the table below and in the figure above.

Connection	Red wire	Blue wire	Green wire	Yellow wire
Monitor	Pin 1	Pin 2	Pin 3	Pin 4
Transmitter	Pin 3	GND	Pin 1	Pin 2

Table 1 Cable Connections

When installing the connector, and to ensure that full ingress protection is achieved, the securing screw (with the O-ring and washer) must be tightened to a minimum torque setting of 3.4 Nm (2.5 ft-lbs). The transmitter cable used must be a minimum diameter of 4.6mm (0.2”).

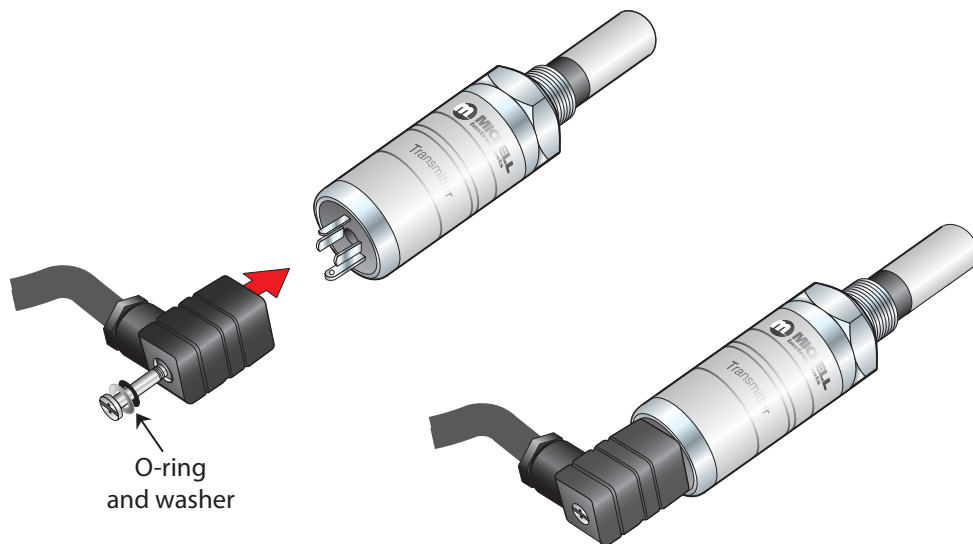

Figure 17 Connector Installation

### 3 OPERATION - MONITOR

**NOTE:** When the instrument is first powered up the display may show a zero value for about 1 second, followed by a flashing OPEN for approximately 5 seconds, before showing a dew-point value. This is normal and does not indicate a problem with the instrument.

There are two levels of operation:

User (No access to programming codes)	Advanced (Access to programming codes)
Changing display brightness	Advanced setpoint programming
Monitoring setpoint values	Analog output calibration and scaling
	Auxiliary (optional) channel set-up
	Setting the engineering units
	Transmitter connection fault relay set-up
	Other related advanced functions

**Table 2** Operation Access Levels

#### 3.1 Set-Up Security Feature

To prevent unauthorized access, the monitor has two DIP-switches that can be accessed by removal of the faceplate (refer to *Figure 18*).

The **ON** position protects that mode, **OFF** makes alterations possible.

- The **SETPOINT LOCKOUT** switch (SW1) enables or disables Setpoint Programming mode.
- The **PROGRAM LOCKOUT** switch (SW2) enables or disables Code Programming mode.

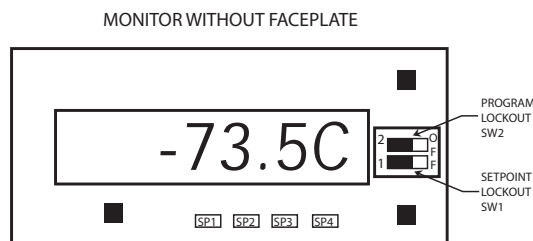

**Figure 18** Location of the Lockout Switches

### 3.2 Selecting the Engineering Units

1. Enter the **PROGRAM UNLOCK** mode (Section 3.1).
2. Press **SETUP** and **↑** to scroll through the menus.

The monitor can display Dew point in °C or °F, PPM(V), lbs/MMSCF or g/m<sup>3</sup> (Natural Gas). The selection of these units is achieved by setting **CODE 4** and **CODE 7** as shown below:

Required Display Unit	CODE 7	CODE 4
Dew point in °C	000	207
Dew point in °F	000	217
PPM <sub>v</sub>	100	-
lbs/MMSCF	200	-
g/m <sup>3</sup> (Natural Gas)	300	-

To set the range and resolution for PPM(V), lbs/MMSCF and g/m<sup>3</sup>, set digit 3 of **CODE 7** to:

0	1	2	3
0	1 – 9999	0.1 – 999.9	0.01 – 99.99
			0.001 – 9.999

For example, by setting **CODE 7** to 102, displays PPM<sub>v</sub> with a resolution of 0.01 to a maximum of 99.99. Should the measured value exceed 100 PPM<sub>v</sub> with this setting, **oVER** will be displayed.

### 3.3 Changing the Setpoint Values

1. Enter the **SETPOINT UNLOCK** mode as described in Section 3.1.
2. Press **SETUP** and **↓** simultaneously to access. The setpoints of the relays are altered by setting **SP\_n** (where n = 1 to 4 and represent SP1 to 4), to the required trip level. These are entered directly in the appropriate engineering units. When displaying PPM(V), then the setpoints are set in PPM(V) units.

The full matrix of codes for alarm configuration can be seen in Appendix B, Setpoint control.

### 3.4 Hysteresis, Make/Break delay & delay type

Associated with each setpoint is a Hysteresis Value, Make delay time, Break delay time and a Delay type. To gain access to these parameters, set **SPC\_n** = xx7, and scroll to the features by pressing the **▲** or **▼** buttons.

The hysteresis value is the value above and below the nominal setpoint at which the relay trips.

The Make delay time is the time delay between the setpoint being reached and the relay energizing. The Break delay time is the time delay between the relay being energized and it de-energizing. The maximum make and break delay time is 9 hours, 6 minutes, 6 seconds, in increments of 1 second.

The setpoint can have four different Delay types:

- **NorM** (normal)
- **rEPt** (repeat)
- **1Shot**
- **PuLSE**

If Delay = <b>NorM</b>	The relay will function normally with the inclusion of the time delays
If Delay = <b>rEPt</b>	The make and break delays will repeat continually until the setpoint source returns to a level that deactivates the setpoint
If Delay = <b>1Shot</b>	The relay will energize after the entered delay period and remain energized
If Delay = <b>PuLSE</b>	The relay will energize, de-energize after the period entered and thereafter will remain de-energized

### 3.5 Analog Output Scaling

1. Enter the **PROGRAM UNLOCK** mode (see Section 3.1).
2. Press **SETUP**, followed by the **▲** button, then **SETUP** again.
3. Press the **▲** or **▼** buttons to scroll through to the **CAL** menu. The analog output can be scaled by setting **CAL** to 061 and setting the zero value to the required output at 4 mA (or 0 V) and the full scale value to the output required at 20 mA (or 10 V).
4. To exit the **CAL** menu press **SETUP**, set **CAL** to 000 and use the **▲** button to scroll through the menus.

See Appendix B - Setup Codes for more information on output scaling options.

### 3.6 Display Brightness Adjustment

1. To adjust the display brightness press the **SETUP** and **↑** buttons simultaneously.
2. The display toggles between [**bri**] and [**5**], where 5 is the default setting.
3. Adjust the display brightness required (from 0 to 7) by pressing the **↑** or **↓** buttons.
4. Press **SETUP** seven times to exit the programming mode.

### 3.7 Digital Communications

The monitor is fitted with ASCII RS232 communication interface as standard (RS485 optional). Communication settings are found as follows:

1. Set CAL to **100**.
2. Press **SETUP** once and then the **↑** or **↓** buttons to change the baud rate. Baud rates are 300, 600, 1200, 2400, 4800, 9600, 19,200 and 57.6 K.
3. Press **SETUP** again to advance to the parity bit and then the **↑** or **↓** buttons to change the parity bit. Parity settings are odd, even or off.
4. Press **SETUP** again to advance to the address settings. Address settings are 0 to 255. **NOTE: address 0 is not a valid RS485 address.**
5. Press **SETUP** again to return to CAL.

The default communication configuration is:

Baudrate	9600
Data bits	8
Parity	none
Flow control	none

The commands used to read and write to the monitor follow the protocol shown below:

Start Character      **s** or **S** for the start character (must be first character in string).

Meter Address        An ASCII number from **0** to **255** for the meter address.

Read/Write        The next character must be an ASCII **R** or **r** for read, or an ASCII **W** or **w** for write. Any other character will abort the operation.

Register Address	The register address for the read/write operation is specified next. It can be either an ASCII number from <b>0</b> to <b>255</b> or registers 1 - 18 can be accessed by entering an ASCII letter from <b>A</b> to <b>R</b> (or <b>a</b> to <b>r</b> , not case sensitive). If the address character is omitted in a read command, the meter will always respond with the data value currently on the display. (The register address must be specified for a write command).  For a full list of the register, that can be read or written to, see Appendix C.
Separator	After the register address in a write command, the next character must be something other than an ASCII number. This is used to separate the register address from the data value. It can be a space or a <b>comma</b> or any other character except a <b>\$</b> or a <b>*</b> .
Data Value	After the separator character, the data value is sent. It must be an ASCII number in the range of <b>-32766</b> to <b>32766</b> .
Terminate	The last character in the message is the message terminator and this must be either a <b>\$</b> or a <b>*</b> . If the <b>\$</b> is used as a terminator, a minimum delay of 50mS is inserted before a reply is sent. If the <b>*</b> is used as a terminator, a minimum delay of 2mS is inserted before a reply is sent. (the <b>\$</b> and <b>*</b> characters must not appear anywhere else in the message string).

### 3.8 Pressure Compensation

Enter the **PROGRAM UNLOCK** mode as described in Section 3.1.

The monitor has the ability to measure pressure in order to provide a pressure compensated value for PPM(V), lbs/MMSCF or g/m<sup>3</sup>.

### 3.9 Using a Pressure Transducer

In order to enable the use of a pressure transducer set **CODE 4** to 307 (dual channel mode), and while pressing **SETUP**, press **▲** once. Release both buttons and keep pressing **SETUP** until **CODE 4** is displayed.

- To display dew point whilst measuring pressure, set **CODE 4** to 307 to show dew point in °C; or 317 for dew point in °F.
- To display pressure in psig set **CODE 6** to 000; or to display pressure in barg set **CODE 6** to 100.

### 3.9.1 Manual Pressure Input Calibration

The pressure input channel must be configured to the range of the pressure transducer. This is achieved by setting **CAL** to 012 and entering values for offset **OFF\_2** and scale **SCA\_2**.

$SCA\_2 = 0.0062 \text{ per } 100 \text{ psig}$

$OFF\_2 = \text{pressure range} - ((20,000 \times (\text{pressure range} \setminus 1000)) \setminus 16)$

For example, for a pressure transducer with a range of 0 to 1000 psig:

$SCA\_2 = 0.0062 \times 10 = 0.0620$

$OFF\_2 = 1000 - ((20,000 \times (1000 \setminus 1000)) \setminus 16) = -250$

If you are using a pressure transducer in barg, convert the value to psig using a multiplier of 14.5. For example, for a pressure transducer with a range of 0 to 100 barg:

$SCA\_2 = 0.0062 \times 14.5 = 0.0899$

$OFF\_2 = 1450 - ((20,000 \times (1450 \setminus 1000)) \setminus 16) = -362$

To exit the **CAL** menu, set **CAL** to 000 and press **SETUP** six times to return to the main screen.

### 3.10 Automatic Pressure Input Calibration

Alternatively, the pressure input can be calibrated using a 4-20 mA source.

1. Connect the current source between pin 2 (-ve) and pin 5 (+ve).
2. Set **CAL** to 022 and press **SETUP**. The monitor will then display **ZERo** and flash **0**.
3. Set the mA source to 4.0 mA and press **SETUP** to set 0 at 4 mA.
4. Press **SETUP** and the monitor will display **SPAN** and flash the full scale pressure value.
5. Set the mA source to 20.0 mA and use the **▲** or **▼** buttons to set the required pressure range.
6. Press **SETUP** to set the required pressure for 20.0 mA.
7. Set **CAL** to 000 and press the **▲** button to leave the menu.

### 3.11 Using a Fixed Pressure Input in Single Channel Mode

In order to display pressure compensated values of ppm<sub>v</sub> without the use of a pressure transducer, enter the pressure value manually.

1. Enter the **PROGRAM UNLOCK** mode (see Section 3.1).
2. Press **SETUP** and the **↑** button to scroll through the menus and select **CODE 7**.
3. Select the required pressure compensated value, i.e. **CODE 7 = 10X** for ppm<sub>v</sub> / ppb<sub>v</sub> and **CAL = 052** (see Table 3).
4. Exit the menus (see Section 3.1) and exit the **PROGRAM UNLOCK** mode.
5. Press **SETUP** for two seconds. The display will show the set pressure. To change the pressure, use the **↑** or **↓** buttons and then press **SETUP** to confirm.

## 4 OPERATION - TRANSMITTER

Operation is very simple assuming the following installation techniques are adhered to:

### Sampling Hints

#### Be Sure the Sample is Representative of the Gas Under Test:

The sample point should be as close to the critical measurement point as possible. Also, never sample from the bottom of a pipe as entrained liquids may be drawn into the sensing element.

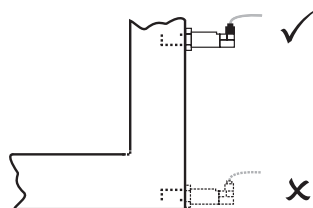

Figure 19 Installation Location

#### Minimize Dead Space in Sample Lines:

Dead space causes moisture entrapment points, increased system response times and measurement errors, as a result of the trapped moisture being released into the passing sample gas and causing an increase in partial vapor pressure.

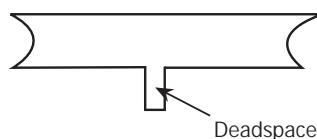

Figure 20 Indication of Dead Space

#### Remove Any Particulate Matter or Oil from the Gas Sample:

Particulate matter at high velocity can damage the sensing element and similarly, at low velocity, they may 'blind' the sensing element and reduce its response speed. If particulate, such as degraded desiccant, pipe scale or rust is present in the sample gas, use an in-line filter, as a minimum level of protection. For more demanding applications Michell Instruments offers a range of sampling systems (for more information contact [www.michell.com](http://www.michell.com)).

#### Use High Quality Sample Tube and Fittings:

Michell Instruments recommends that, wherever possible, stainless steel tubing and fittings should be used. This is particularly important at low dew points since other materials have hygroscopic characteristics and adsorb moisture on the tube walls, slowing down response and, in extreme circumstances, giving false readings. For temporary applications, or where stainless steel tubing is not practical, use high quality thick walled PTFE tubing.

#### Position Transmitter away from Heat Source:

It is recommended, as good instrumentation practice, that the transmitter is placed away from any heat source to avoid adsorption/desorption.

## 5 MAINTENANCE

### Calibration

Routine maintenance of the Cermet II Transmitter is confined to regular re-calibration by exposure of the transmitter to sample gases of known moisture content to ensure that the stated accuracy of the transmitter is maintained. Calibration services traceable to the UK *National Physical Laboratory* (NPL) and the US *National Institute of Standards and Technology* (NIST) are provided by Michell Instruments.

Michell Instruments offers a variety of re-calibration and exchange transmitter schemes to suit specific needs. A Michell representative can provide detailed, custom advice (for Michell Instruments' contact information go to [www.michell.com](http://www.michell.com)).

### Transmitter Guard Replacement

The transmitter is supplied with a white HDPE guard (standard) or a stainless steel guard (if specified at time of order). The method of replacement is the same for both types.

#### HDPE Guard

The HDPE guard provides <math>10\mu\text{m}</math> protection to the dew-point sensor. It is designed to show any contamination and the guard should be changed if the surface becomes discolored.

When replacing the guard, care should be taken to handle the guard by the bottom part only. Replacement guards (EA2-HDPE) - pack of 10 - can be obtained by contacting Michell Instruments ([www.michell.com](http://www.michell.com)) or your local distributor.

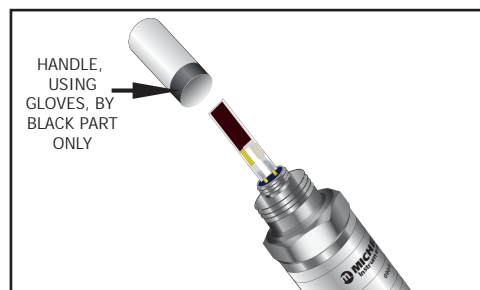

**Figure 21** Replacement of HDPE Guard

#### Stainless Steel Guard

The stainless steel guard provides <math>80\mu\text{m}</math> protection to the dew-point sensor. It is designed to show any contamination and the guard should be changed if the surface becomes discolored.

When replacing the guard, care should be taken to handle the guard by the bottom part only. A replacement guard (SSG) can be obtained by contacting Michell Instruments ([www.michell.com](http://www.michell.com)) or your local distributor.

### Bonded Seal

If the installed bonded seal gets damaged or lost, a pack of 5 replacement bonded seals can be obtained by contacting Michell Instruments, or your local distributor, and quoting part number BS-58-PK5.

# Appendix A

## Technical Specifications

## Appendix A Technical Specifications

<b>Monitor</b>	
Display	5 digit LED 7-segment digit, 14.2 mm(0.56")
Display Color	Red
Temperature and Alarm Indicators	Red LED's
<b>Performance Specifications</b>	
Measurement Ranges	-19999 to 99999
Accuracy	Dew point $\pm 0.5^{\circ}\text{C}$ ( $\pm 1.0^{\circ}\text{F}$ ) ppm <sub>v</sub> , lbs/MMSCF and g/m <sup>3</sup> $\pm 1\%$ of reading Pressure $\pm 0.5\%$ full-scale reading
<b>Electrical Specifications</b>	
Dew-Point Input Channel	Digital signal from Michell dew-point transmitter
Pressure Input Channel (optional)	2-wire pressure transducer, 4-20 mA (loop-powered)
Output Scaled Range	Dew point: -100 to +20°C Moisture content in gas: 0 to 9999 ppm <sub>v</sub> , 0 to 1000 lbs/MMSCF and g/m <sup>3</sup> Non-standard available upon request
Re-transmission Output Signals	<b>Standard:</b> 4-20 mA <b>Optional:</b> 0-20 mA (max load 500 $\Omega$ ) or 0 - 10 V optional (min load 5 K $\Omega$ ) User scaleable
Alarm Relays	<b>Standard:</b> Two relays SP1 and SP2, fully user programmable Form C contacts rated 10 A, 240 V AC or 8 A, 24 V DC Non-inductive load <b>Optional:</b> Two extra relays, SP3 and SP4, fully user programmable Form A contacts rated 5 A, 240 V AC or 5 A, 30 V DC Non-inductive load
Power Connection	2m (6.56ft), 3 wire
Power Supply	<b>Standard:</b> 85 to 265 V AC, 50/60 Hz or 95 to 370 V DC <b>Optional:</b> 18 to 36 V AC or 9 to 60 V DC
Power Consumption	10 W max
Transmitter Cable	Copper braid screened cable, 4 core 7/0.2 (0.22mm <sup>2</sup> ), stranded, tinned copper conductors, PVC, insulated, Melinex taped, black PVC outer Fitted with transmitter connector and terminations for monitor Max length 1000m (3280ft)
<b>Operating Specifications</b>	
Operating Mode	Continuous
Operating Temperature	0 to +50°C (+32 to +122°F)
<b>Mechanical Specifications</b>	
Ingress Protection	<b>Standard:</b> IP54 / NEMA 12 (at front), <b>Optional:</b> Extra protection cover IP66 / NEMA 4
Dimensions	96 x 48 x 142mm (3.8 x 1.9 x 5.6")
Mounting	Panel mounting (1/8 DIN cut out 92 x 45mm (3.62 x 1.77"))
Weight	0.6kg (1.32lbs)

<b>Transmitter</b>									
<b>Performance Specifications</b>									
Measurement Range	-100 to +20°Cdp (-148 to +68°Fdp) dew point								
Accuracy	±1°C dew point (+20 to -60°C) (+68 to -76°F) ±2°C dew point (-60 to -110°C) (-76 to -166°F)								
Response Time	5 mins to T95 (dry to wet)								
Repeatability	0.5°Cdp (0.9°Fdp)								
Calibration	13 point calibration with traceable 7 point calibration certificate								
<b>Electrical Specifications</b>									
Output Signal	4-wire connection, digital signal User-configurable over range								
Output	Dew point								
Output Scaled Range	Dew point: -100 to +20°C Moisture content in gas: 0 to 9999 ppm <sub>v</sub> , 0 to 1000 lbs/MMSCF and g/m <sup>3</sup> Non-standard available upon request								
Supply Voltage	12 to 28 V DC								
Load Resistance	Max 250 Ω @ 12 V (500 Ω @ 24 V)								
Current Consumption	20 mA max								
CE Conformity	2004/108/EC								
<b>Operating Specifications</b>									
Operating Temperature	-40 to +60°C (-40 to +140°F)								
Operating Pressure	45 MPa (450 barg ) max								
Flow Rate	Mounted in standard sampling block: 1 to 5 NI/min (2.1 to 10.6 scfh) Direct insertion: 0 to 10 m/sec (0 to 32.8 fps)								
Temperature Coefficient	Temperature compensated across operating temperature range								
<b>Mechanical Specifications</b>									
Ingress Protection	IP66 in accordance with standard BS EN60529:1992 NEMA 4 in protection accordance with standard NEMA 250-2003								
Housing Material	316 stainless steel								
Filter (sensor protection)	<b>Standard:</b> HDPE Guard < 10µm <b>Optional:</b> 316 stainless steel sintered guard < 80µm								
Process Connection & Material	5/8" - 18 UNF 316 stainless steel								
Weight	150g (5.3oz)								
Interchangeability	Fully interchangeable transmitter								
Electrical Connection	Hirschmann GDS series (DIN 4350-C)								
Diagnostic Conditions (factory programmed)	<table border="1"> <thead> <tr> <th>Condition</th> <th>Output</th> </tr> </thead> <tbody> <tr> <td>Sensor fault</td> <td>23 mA</td> </tr> <tr> <td>Under-range dew point</td> <td>4 mA</td> </tr> <tr> <td>Over-range dew point</td> <td>20 mA</td> </tr> </tbody> </table>	Condition	Output	Sensor fault	23 mA	Under-range dew point	4 mA	Over-range dew point	20 mA
Condition	Output								
Sensor fault	23 mA								
Under-range dew point	4 mA								
Over-range dew point	20 mA								
Digital Diagnostic Communications	Communications RS485, 2-wire Modbus RTU								

# Appendix B

## Setup Codes

## Appendix B Setup Codes

### CAL Calibration modes for input and output DEFAULT VALUE = 052

Digit	1st digit (left most) Calibration Mode	2nd digit Calibration Function	3rd digit Object for Calibration
0	Calibration functions as per 2nd and 3rd digit	No function	No function
1	Set baud rate, parity and serial address	Manual calibration (channel as per 3rd digit)	Processed result (dew point, ppm <sub>v</sub> , lbs/MMSCF, g/m <sup>3</sup> )
2	N/A	N/A	Pressure input
3	N/A	N/A	N/A
4	N/A	N/A	N/A
5	N/A	Manual adjust	N/A
6	N/A	Analog output scaling (analog channel as per 3rd digit)	N/A

### CODE 1 Tendency Indication, Additional LED's, Display data source, Flashing, Decimal points, Rounding DEFAULT VALUE = 200

Digit	1st digit (left most) Additional LED's	2nd digit Display Data Source	3rd digit 0 only (No Function)
0	LED annunciators are always off	Processed data - result (dew point, ppm <sub>v</sub> , lbs/MMSCF, g/m <sup>3</sup> )	N/A
1	LED annunciators are on when relays are de-energized	Processed data - channel 1 (dew point only)	N/A
2	LED annunciators are on when relays are energized	Processed data - pressure	N/A

### CODE 3 Serial mode and analog output source DEFAULT VALUE = 000

Digit	1st digit (left most) Serial Mode	2nd digit Analog Output 1 Source	3rd digit 0 only (No Function)
0	ASCII mode	Analog output 1 from processed result data (dew point, ppm <sub>v</sub> , lbs/MMSCF, g/m <sup>3</sup> )	N/A
1	N/A	Analog output 1 from processed data (dew point only)	N/A
2	N/A	Analog output 1 from processed data (pressure)	N/A

**CODE 4 Channel 1 Measurement task, Sampling rate  
DEFAULT VALUE = 207**

Digit	1st digit (left most) Analog Sample Rate	2nd digit Analog Output 1 Source	3rd digit 0 only (No Function)
0	N/A	Dew point in degrees C	N/A
1	N/A	Dew point in degrees F	N/A
2	Single channel (50 Hz)	N/A	N/A
3	Dual channel (50 Hz)	N/A	N/A

**CODE 6 Channel 2 Measurement task  
DEFAULT VALUE = 000**

Digit	1st digit (left most) Measurement Task	2nd digit 0 only (No Function)	3rd digit 0 only (No Function)
0	Pressure in psig	N/A	N/A
1	Pressure in barg	N/A	N/A

**CODE 7 Result processing  
DEFAULT VALUE = 000**

Digit	1st digit (left most) Measurement Task	2nd digit 0 only (no function)	3rd digit Range for Result
0	Dew point	N/A	1 – 9999
1	ppm <sub>v</sub>	N/A	1 – 999.9
2	lbs/MMSCF	N/A	0.01 – 99.99
3	g/m <sup>3</sup> (Natural Gas)	N/A	0.001 – 9.999

**Setpoint control 1 – 6 Relay latching, relay setup, source  
DEFAULT VALUE = 000 (Prog/Down menu after setpoints)**

Digit	1st digit (left most) Relay Sense	2nd digit Setpoint Source	3rd digit Setpoint Function SP1 – SP4
0	Relay energized above setpoint value	Processed result data (dew point, ppm <sub>v</sub> , lbs/MMSCF, g/m <sup>3</sup> )	No function
1	Relay energized below setpoint value	Dew point only	Relay latched
2	N/A	Pressure	De-energized relay
3	N/A	Open transmitter connection	N/A
4	N/A	Open / short circuit transmitter	Relay off for open transmitter connection
5	N/A	Open / short circuit thermistor	Relay on for open transmitter connection
6	N/A	All transmitter faults	Relay toggles at 1 Hz for transmitter connection fault
7	N/A	N/A	Set-up hysteresis, make/break delay and delay type

# Appendix C

## Register Settings Accessible by Digital Communication

## Appendix C Register Settings Accessible by Digital Communication

Register Number	Function	Read Only
1	Alarm Status	
2	N/A	
3	Processed Data – Result	✓
4	Processed Data – Channel 1 (dew-point)	✓
5	Processed Data – Channel 2 (pressure)	✓
6	Setpoint 1	
7	Setpoint 2	
8	Setpoint 3	
9	Setpoint 4	
10 to 23	N/A	
24	Scale Value – Result	
25	Scale Value – Channel 1	
26	Scale Value – Channel 2	
27	Offset Value – Result	
28	Offset Value – Channel 1	
29	Offset Value – Channel 2	
30 to 33	N/A	
34	D/A Zero – Analogue O/P 1	
35	N/A	
36	D/A Full Scale – Analogue O/P 1	
37 to 64	N/A	
65	Hysteresis - Setpoint 1	
66	Hysteresis - Setpoint 2	
67	Hysteresis - Setpoint 3	
68	Hysteresis - Setpoint 4	
69 to 70	N/A	
71	Make Delay - Setpoint 1	
72	Make Delay - Setpoint 2	
73	Make Delay - Setpoint 3	
74	Make Delay - Setpoint 4	
75 to 76	N/A	
77	Break Delay - Setpoint 1	
78	Break Delay - Setpoint 2	
79	Break Delay - Setpoint 3	
80	Break Delay - Setpoint 4	
81 to 128	N/A	
129	Cal Mode	
130	Code 1	
131	Code 2	
132	Code 3	

133	Code 4	
134	Code 5	
135	Code 6	
136	Code 7	
136	Code 8	
138 to 141	Reserved	
142	Setpoint 1 Control Register	
143	Setpoint 2 Control Register	
144	Setpoint 3 Control Register	
145	Setpoint 4 Control Register	
146 to 147	N/A	
148	Brightness	
149	Baudrate Settings	
150	Serial Address	
151 to 152	N/A	
153	Model Number	✓
154	Version Number	✓
155 to 192	N/A	
193	Delay Type – Setpoint 1	
194	Delay Type – Setpoint 2	
195	Delay Type – Setpoint 3	
196	Delay Type – Setpoint 4	

# Appendix D

## EU Declaration of Conformity

## Appendix D EU Declaration of Conformity

## EU Declaration of Conformity



Manufacturer: **Michell Instruments Limited**  
**48 Lancaster Way Business Park**  
**Ely, Cambridgeshire**  
**CB6 3NW. UK.**



On behalf of the above named company, I declare that, on the date that the equipment accompanied by this declaration is placed on the market, the equipment conforms with all technical and regulatory requirements of the listed directives.

## CERMET II

and complies with all the essential requirements of the EU directives listed below.

**2004/108/EC EMC Directive**  
 and (effective from 20<sup>th</sup> April 2016)  
**2014/30/EU EMC Directive**

and (effective from 22<sup>nd</sup> July 2017)

**2011/65/EU Restriction of Hazardous Substances Directive (RoHS2)**

RoHS2 EU Directive 2011/65/EU (Article 3, [24]) states, "*industrial monitoring and control instruments means monitoring and control instruments designed exclusively for industrial or professional use*". (mandatory compliance effective date 22<sup>nd</sup> July 2017).

and has been designed to be in conformance with the relevant sections of the following standards or other normative documents.

EN61326-1:1997	Electrical equipment for measurement, control and laboratory use – EMC requirements –Class B (emissions) and Industrial Locations (immunity).
EN61010-1:2010	Safety Requirements for Electrical Equipment for Measurement, Control, and Laboratory Use - Part 1: General Requirements

Andrew M.V. Stokes, Technical Director

April 2016

EUD Cermet II Issue 02

# Appendix E

## Quality, Recycling & Warranty Information

## Appendix E Quality, Recycling & Warranty Information

### E.1 Pressure Equipment Directive (PED) 97/23/EC

The above Directive has been implemented in United Kingdom Law by the Pressure Equipment Regulations 1999.

The Regulations require that all pressure equipment and assemblies within the scope of the Pressure Equipment Directive must be safe when placed on the market or put into service.

Michell Instruments' products have been assessed and, as referenced against the Classification Charts detailed in Annex II of the Directive, do not fall into the requirements for CE marking compliance with the Pressure Equipment Directive.

Article 3, paragraph 3 states that any product containing a pressurized fluid that does not qualify for compliance should, nevertheless, be constructed with Sound Engineering Practice (SEP).

Michell Instruments attests here that its products have been designed, manufactured & tested to assure safe operation, and in accordance with Sound Engineering Practices.

### E.2 Recycling Policy



Michell Instruments is concerned with the protection of the environment. It is our commitment to reduce and eliminate from our operations, wherever possible, the use of substances which may be harmful to the environment. Similarly, we are increasingly using recyclable and/or recycled material in our business and products wherever it is practical to do so.

To protect natural resources and to promote material reuse, please separate batteries from other types of waste and recycle responsibly. If batteries are not properly disposed of, these substances can cause harm to human health and the environment.

The product that you have purchased may contain recyclable and/or recycled parts and we will be happy to provide you with information on these components if required. For further information please see the following sections.

### E.3 WEEE Compliance

#### Directive 2012/19/EU 4 July 2012 on Waste Electronic and Electrical Equipment (WEEE)

The Waste Electronic and Electrical Equipment (WEEE) Directive places rules upon European manufacturers of electrical and electronic equipment. The directives' aim is to reduce the impact that electronic devices have on the environment.

Michell Instruments is in full compliance with the WEEE Directive and is registered with an approved recycler (Registration No. WEE/JB0235YW) and treats the requirement of the directive and the protection of the environment with the utmost importance. All Michell Instruments' products are appropriately marked indicating their requirement for recycling.

It may be required to return certain instruments for treatment at the end of their working life.

Feb 2013

## E.4 RoHS2 Compliance

### Directive 2011/65/EU of the European Parliament and of the Council of 8 June 2011

The Restriction of Hazardous Substances (RoHS) Directive places rules upon European manufacturers of electrical and electronic equipment. The directives' aim is to reduce the impact that electronic devices have on the environment.

According to the EC Directive 2002/95/EC, Michell Instruments' products qualify as Category 9, Control and Monitoring Equipment. Under the 2002/95/EC Directive, Category 9 products are exempt from compliance with the Directive.

However, the careful design of all Michell Instruments' products takes into consideration the requirements of the Directive and, wherever possible, compliance is achieved. All future products will be developed entirely using compliant materials. Furthermore, Michell Instruments is taking active steps to remove non-compliant materials and components from existing products wherever these may occur. Presently, none of the non-compliant materials are known to occur in Michell Instruments' products.

The new Directive 2011/65/EU (RoHS2) entered into force on 21 July 2011 and required all Member States to transpose the provisions into their respective national laws by 2 January 2013.

Under the provisions of the RoHS2 EU Directive 2011/65/EU (Article 3, [24]) defines 'Control and Monitoring Equipment' specifically as 'monitoring and control instruments designed exclusively for industrial or professional use'.

RoHS2 EU Directive 2011/65/EU states the closing date for compliance of any Control and Monitoring Equipment product sold into the EU market place as 22nd July 2017.

However, the careful design policy of all Michell Instruments' products continues to attain compliance in the shortest practical timescales and strives to ensure that less than 0.1% of total mass per product, of all non-compliant materials, appear within them. Michell Instruments continues to monitor suppliers and material sources to ensure that compliance of goods provided is maintained.

January 2013

## E.5 Warranty

Unless otherwise agreed, the Supplier warrants that, as from the date of delivery for a period of 12 months, the goods and all their component parts, where applicable, are free from any defects in design, workmanship, construction or materials.

The Supplier warrants that the services undertaken shall be performed using reasonable skill and care, and be of a quality conforming to generally accepted industry standards and practices.

Except as expressly stated, all warranties whether express or implied, by operation of law or otherwise, are hereby excluded in relation to the goods and services to be provided by the Supplier.

All warranty services are provided on a return to base basis. Any transportation costs for the return of a warranty claim shall reside with the Customer.

## E.6 REACH Compliance

Regulation (EC) No. 1907/2006

Registration, Evaluation, Authorisation and Restriction of Chemicals (REACH)

Michell Instruments is a manufacturer of moisture measurement and gas analysis instrumentation and is a 'downstream' user of chemicals, as described by the EU Council Directive 76/769/EEC. The products we supply are not raw chemical products (goods).

Under normal and reasonably foreseeable circumstances of application, the goods supplied to you shall not contain or release any prohibited chemicals. No listed SVHC (Substances of Very High Concern) appear within products manufactured by Michell Instruments. Therefore the 0.1% mass per product, or total usage of 1 tonne/year, will never be exceeded. For these reasons we are neither required by obligation for registration nor for the creation of material safety data sheets (MSDS) for our products.

Our continued review of the SVHC Candidate List and latest additions is to ensure we remain compliant.

Michell Instruments maintains a hazardous material register in which MSDS data sheets are collated, and we will check that our suppliers will comply to REACH requirements for all materials and substances we use in the processes of our manufacturing.

In the unlikely event that any chemicals of concern appear in our products in quantities greater than 0.1% of total mass per product we will immediately inform you by correspondence according to the REACH Article 33 requirements. Our current appraisal is, however, that we do not expect or foresee such an incidence.

January 2013

## E.7 Return Policy

If a Michell Instruments' product malfunctions within the warranty period, the following procedure must be completed:

1. Notify a Michell Instruments' distributor, giving full details of the problem, the model variant and the serial number of the product.
2. If the nature of the problem indicates the need for factory service then the instrument should be returned to Michell Instruments, carriage prepaid, preferably in the original packaging, with a full description of the fault and the customer contact information.
3. Upon receipt, Michell Instruments will evaluate the product to determine the cause of the malfunction. Then, one of the following courses of action will be taken:
  - If the fault is covered under the terms of the warranty, the instrument will be repaired at no cost to the owner and returned.
  - If Michell Instruments determines that the fault is not covered under the terms of the warranty, or if the warranty has expired, an estimate for the cost of the repairs, at standard rates, will be provided. Upon receipt of the owner's approval to proceed, the product will be repaired and returned.

## E.8 Calibration Facilities

Michell Instruments' calibration facilities are among the most sophisticated in the world and have been recognized for their excellence.

Traceability to the National Physical Laboratory (NPL) UK is achieved through our UKAS Accreditation (Number 0179). This covers dew point over the range -90 to +90°C (-130 to +194°F) and also Relative Humidity.

Dew-point calibrations are also traceable to the National Institute for Standards & Technology (NIST) USA over the range -75 to +20°C (-103 to +68°F).

**NOTE: Standard traceable calibration certificates for instruments and sensors are not issued under our UKAS accreditation.**

## E.9 Manufacturing Quality

Michell Instruments is registered with the British Standards Institute for Quality Assurance to:

BS EN ISO 9001: 2008

Rigorous procedures are performed at every stage of production to ensure that the materials of construction, manufacturing, calibration and final test procedures meet the requirements laid down by our BSI approved Quality System.

Please contact Michell Instruments ([www.michell.com](http://www.michell.com)) if the product does not arrive in perfect working order.

## E.10 FCC (EMC Requirements for North America)

This device complies with part 15 of the FCC Rules. Operation is subject to the following two conditions:

1. This device may not cause harmful interference.
2. This device must accept any interference, including interference that may cause undesired operation.

This equipment has been tested and found to comply with the limits for a Class A digital device, pursuant to part 15 of the FCC Rules. These limits are designed to provide reasonable protection against harmful interference when the equipment is operated in a commercial environment. This equipment generates, uses, and can radiate radio frequency energy and, if not installed and used in accordance with the user manual, may cause harmful interference to radio communications. Operation of this equipment in a residential area is likely to cause harmful interference in which case the user will be required to correct the interference at his own expense. This product must be operated as per the operating instructions provided. Do not make any alterations or modifications to the product. Any unauthorized alterations or modifications made to this product may require you to stop operating the product.

### **Canadian Radio Interference Regulations.**

This Class A digital product complies with Canadian ICES-001. Règlement canadien sur les interférences radio. Ce produit numérique de classe A est conforme à la norme NMB-001.

# Appendix F

## Return Document & Decontamination Declaration

Appendix F Return Document & Decontamination Declaration

**Decontamination Certificate**

**IMPORTANT NOTE:** Please complete this form prior to this instrument, or any components, leaving your site and being returned to us, or, where applicable, prior to any work being carried out by a Michell engineer at your site.

Instrument			Serial Number	
Warranty Repair?	YES	NO	Original PO #	
Company Name			Contact Name	
Address				
Telephone #			E-mail address	
Reason for Return /Description of Fault:				
Has this equipment been exposed (internally or externally) to any of the following? Please circle (YES/NO) as applicable and provide details below				
Biohazards			YES	NO
Biological agents			YES	NO
Hazardous chemicals			YES	NO
Radioactive substances			YES	NO
Other hazards			YES	NO
Please provide details of any hazardous materials used with this equipment as indicated above (use continuation sheet if necessary)				
Your method of cleaning/decontamination				
Has the equipment been cleaned and decontaminated?			YES	NOT NECESSARY
Michell Instruments will not accept instruments that have been exposed to toxins, radio-activity or bio-hazardous materials. For most applications involving solvents, acidic, basic, flammable or toxic gases a simple purge with dry gas (dew point <-30°C) over 24 hours should be sufficient to decontaminate the unit prior to return. <b>Work will not be carried out on any unit that does not have a completed decontamination declaration.</b>				
<b>Decontamination Declaration</b>				
I declare that the information above is true and complete to the best of my knowledge, and it is safe for Michell personnel to service or repair the returned instrument.				
Name (Print)			Position	
Signature			Date	



**NOTES:**



Instrument Expert  
Original factory  
packaging  
[www.keruiyiqi.cn](http://www.keruiyiqi.cn)



<http://www.michell.com>